

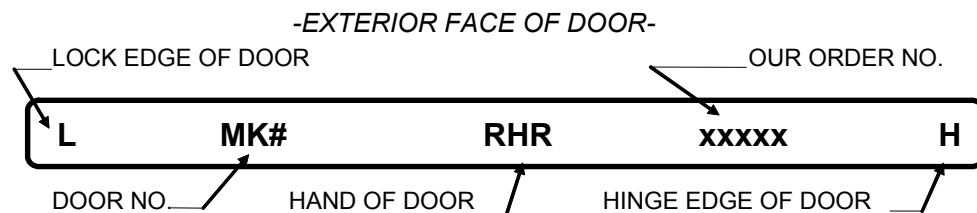

5224 FM 802 Brownsville, TX 78521 P: 800.444.6924
FRPorders@phoenixdoorsystems.com
www.chem-pruf.com

**INSTALLATION INSTRUCTIONS FOR HEAVY DUTY NON-FIRE AND 20
MINUTE RATED FRP DOORS**

IDENTIFY DOOR to be hung by inspection of markings on door edge. Each door supplied is factory marked on the *top edge* to identify the door identification number, hand, and proper orientation. Note that any hinge mortises, cylindrical lock drilling, mortise lock cutout, and/or flush bolt mortises have been factory pre-machined.



VIEW OF TOP EDGE DOOR MARKING

CHECK DOOR BEFORE HANGING— Take a few moments to inspect the door for correct size, swing and hardware preparation before proceeding, *ESPECIALLY BEFORE REMOVAL OF ANY EXISTING UNIT*. Notify your distributor, Chem-Pruf sales representative, or the factory immediately of any discrepancies.

LAYOUT HARDWARE HOLES AND CUTOUTS on door faces, using the templates provided with the hardware items. *Be sure to lay the door on a soft surface to avoid damaging the faces.*

RECHECK LAYOUT PRIOR TO DRILLING OR MACHINING DOOR. Verify each hole pattern with the actual hardware item where possible. Make sure each pattern is correctly located from the door edges (backset). Inspect each hardware item for proper fastener type and quantity. *MIS-DRILLED HOLES OR CUTOUTS CANNOT BE PROPERLY FIELD REPAIRED.*

MACHINE AND/OR DRILL DOOR using standard high speed steel (HSS) hole saws, jig saw blades (14 teeth/inch min.) and twist drills. Make sure to use the proper drill bit size for either wood/sheet metal screws or thru-bolts. Do not attempt to cut threads into the FRP door for machine screws. Always drill a 1/4" diameter pilot hole before drilling larger diameter holes.

Standard mill or rattail files may be used to enlarge holes or cutouts. Wood chisels may also be used when required. *Always use sharp tools, and sharpen often.*

HANG DOOR– If **surface mounted hinges** are used, shim the door in the opening leaving 1/8" clearance at the top of the door and equal spaces along each side (but not more than 3/16" at lock edge). Use wedges at the bottom of the door to hold it in place. Carefully align the hinges on a common vertical line then drill through the door with a 1/4" diameter bit, using each hinge as a drilling template. Counterbore the hinge holes from the back side of the door with a 3/8" diameter bit per the hinge manufacturers' instructions. *Use the thru-bolts or grommet nuts supplied with the hinges to hang the door.*

If **mortised hinges** are used, screw holes are factory predrilled on doors using standard Chem-Pruf hinge locations. *Use only Chem-Pruf supplied screws to hang the door– do not use the screws furnished with the hinges.*

If **mortised continuous hinges** are used, field drilling of pilot holes will be required. Chem-Pruf recommends that a minimum of a #12 x 3" sheet metal screw in combination with a 5/32" pilot hole be used for hinge attachment. Shorter or smaller screws may not provide sufficient pullout resistance.

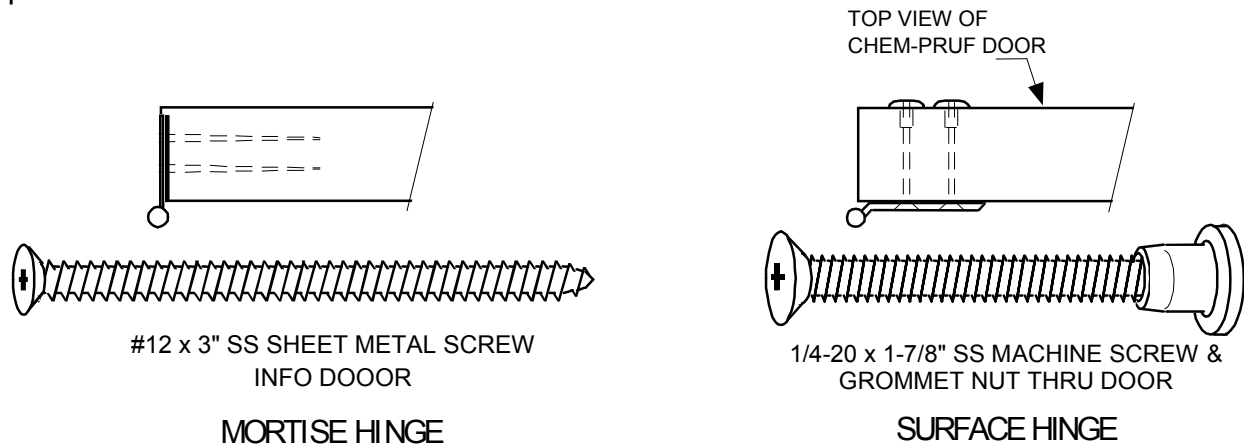

TYPES OF HINGES WITH FASTENERS REQUIRED FOR FRP DOORS

FASTENERS - Sheet metal screws with full length threads are required for any mortise hardware installation. All closers and other surface mounted hardware must be installed with through bolts thru the faces of the doors. Self-tapping or combination wood/metal screws shall not be used at any time. Failure to follow these fastener requirements may void the Chem-Pruf product warranty.

INSTALL BALANCE OF HARDWARE ITEMS at identified reinforcement locations and adjust as necessary for proper door fit and operation. Install threshold, then weatherstripping, only after all else has been completed.

CHEM-PRUF

5224 FM 802 - BROWNSVILLE, TX 78521

WWW.CHEM-PRUF.COM - FRPORDERS@PHOENIXDOORSYSTEMS.COM - 800-444-6924