



5224 FM 802 Brownsville, TX 78521 P: 800.444.6924

FRPorders@phoenixdoorsystems.com

www.chem-pruf.com

## INSTALLATION INSTRUCTIONS FOR NON-FIRE AND 20 MINUTE RATED FRP DOOR FRAMES

### ***-GROUTED IN WITH NEW MASONRY-***

**ASSEMBLE FRAME** using stainless steel screws and FRP angle clips provided. Match up frame "Mk." numbers. Make sure the header is oriented so that door closer reinforcement is located towards the *hinge* jamb. Prior to installation, check all parts for size and correctness before proceeding. *Check to insure that correct opening width exists between jamb uprights and that corner connections are not twisted.*

**SET FRAME** on slab, drill and set bottom anchors, and loosely bolt frame to slab. Use a level on each jamb and across the header to set square and plumb. Use shims under bottom angle clips to level header if necessary. Finally, make sure that jambs are not twisted and that proper opening dimension is maintained on *both* inside and outside frame faces. Now tighten bottom anchors. *It is critical to make sure that frame is set plumb and square, while maintaining the correct opening dimension across the bottom of the frame.*

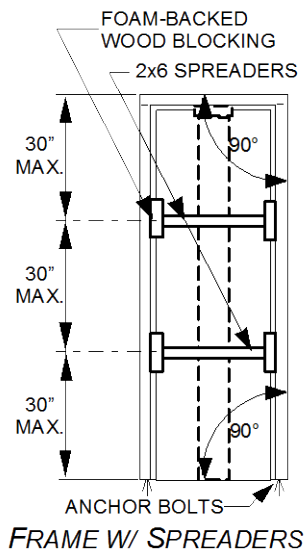

**SECURELY BRACE** to plumb and square setup and maintain inside opening size during placement of block. Use a minimum of two (depending on frame height) horizontal 2x6 spreaders to maintain proper opening width. *Butt 2x6's against smaller blocks with soft foam sheet behind (from door packaging material) to prevent damage to factory finish.* For wider frames, use a vertical spreader(s) to prevent header sag. Use inclined 2x4 braces (not shown) from the upper corners of the frame to slab or grade to hold the frame square and upright. *Recheck frame for correct setup prior to erection of block masonry.*

**ERECT BLOCK MASONRY**, starting adjacent to frame. Fill frame cavities with grout/mortar as courses rise. Use grouted wire anchors at every third course of block (each 24" of height). Frames wider than 5 feet also require a center bolted anchor in the header, which is installed after placing the lintel. Periodically check frames for proper inside opening size as masonry continues.

**IT IS THE INSTALLER'S RESPONSIBILITY TO INSURE THE PREVENTION OF BOWING, TWISTING OR WARPING OF JAMBS DUE TO MORTAR OR BLOCK PRESSURE OR OTHER FACTORS DURING WALL ERECTION. DOOR SIZE CANNOT BE LATER ADJUSTED TO COMPENSATE FOR IMPROPER FRAME INSTALLATION!** The techniques outlined above are general procedures that may not be appropriate for every opening. Some circumstances may require special methods.

## ***-BOLTED INTO EXISTING OPENING-***

**ASSEMBLE FRAME**, per instructions at top of page 1. Note: If frame is furnished to wrap stud-wall construction (frame is larger than wall opening), pre-assembly is not required and frame may be assembled sequentially within the opening, starting with the header.

**CHECK FRAME BEFORE INSTALLATION**– Prior to installation, and removal of any existing unit, check all parts for size and correctness before proceeding! Check for correct opening width and height inside frame and that corner connections are not twisted. NOTIFY YOUR DISTRIBUTOR, CHEM-PRUF SALES REPRESENTATIVE OR THE FACTORY IMMEDIATELY OF ANY DISCREPANCIES.

**SET FRAME** in the opening, using shims as necessary to take up excess clearance, and under jamb uprights to level header. *It is critical at this point to make sure that frame is set plumb and square.* Drill anchor holes in wall. Note that frames wider than 52 inches require a center bolted anchor in the header as well. Use shims as necessary to adjust for plumb on hinge jamb and tighten the hinge jamb anchors only. *Recheck to make sure that hinge jamb is perfectly plumb.*

**HANG DOOR** - If **mortised hinges** are used, screw holes are factory predrilled on frames using standard Chem-Pruf hinge locations. *Use only Chem-Pruf supplied screws to hang the door on the frame– do not use the screws furnished with the hinges.*

If **continuous hinges** are used, field drilling of pilot holes will be required. Chem-Pruf recommends that a minimum of a #12 x 1" sheet metal screw in combination with a 5/32" pilot hole be used for hinge attachment. Shorter or smaller screws may not provide sufficient pullout resistance.

Check for proper operation by gently closing door against the latch side jamb. Install and adjust shims behind latch jamb as necessary to maintain a uniform 1/8" (±) clearance between the door edge and frame. Now check that door face uniformly contacts latch side door stop at both top and bottom corners. Adjust jamb if necessary by pushing the bottom (or top) of the jamb toward the inside (or outside) face until door stop is parallel with the face of door. (Note: This may cause the latch jamb to be negligibly out of plumb, but is necessary in some cases to insure proper door operation and sealing.) Finally, tighten the remaining anchor bolts to secure the frame. Caulk around inside and outside perimeter of frame, first using backer rod inserts if necessary.

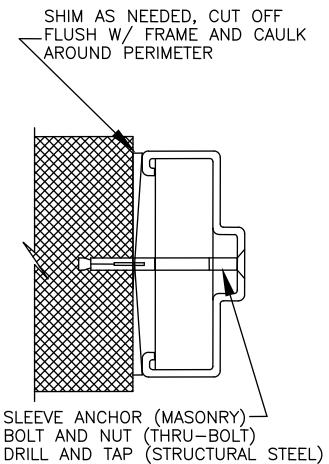

SECTION THRU JAMB

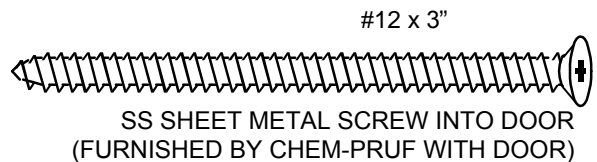
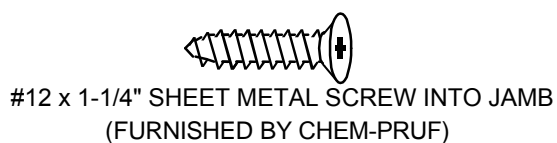

### ***BUTT HINGE FASTENERS FOR FRP FRAME AND DOOR***

**INSTALL BALANCE OF DOOR HARDWARE** and check again for proper operation. Adjust hardware as necessary to fine tune door operation. Finally, install weather-stripping, sweep, and/or threshold, if applicable. Recheck installation after 1 week.

CHEM-PRUF

5224 FM 802 - BROWNSVILLE, TX 78521

WWW.CHEM-PRUF.COM - FRPORDERS@PHOENIXDOORSYSTEMS.COM - 800-444-6924