

OPTION W-BM
WRAP MASONRY

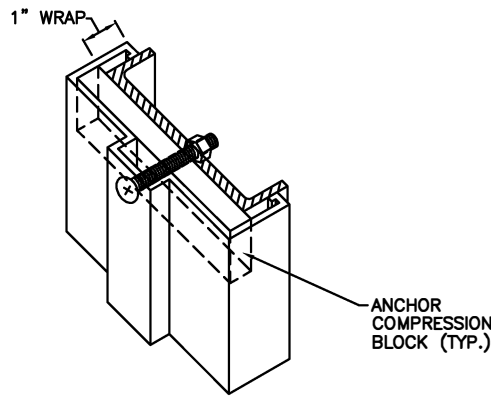

OPTION W-BS
WRAP STEEL

ANCHOR
COMPRESSION
BLOCK (TYP.)

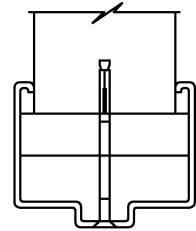

4" HEAD ANCHOR
WHERE REQUIRED

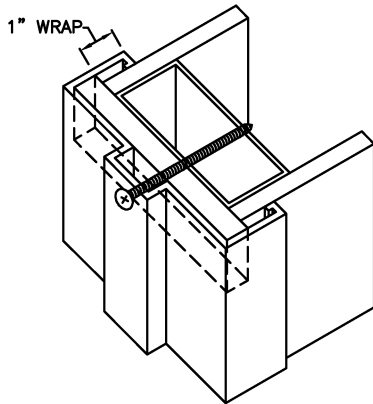

OPTION W-MS1
WRAP METAL STUD

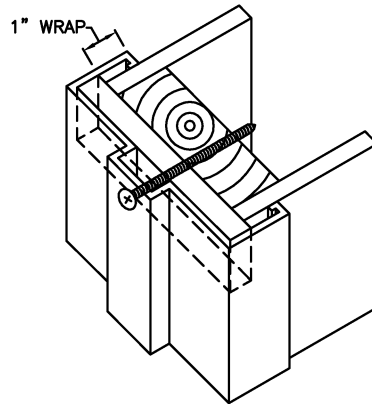

OPTION W-WS1
WRAP WOOD STUD

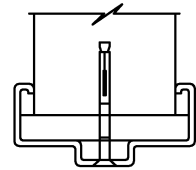

2" HEAD ANCHOR
WHERE REQUIRED

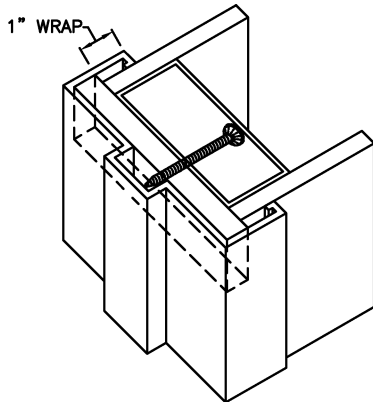

OPTION W-MS2
WRAP METAL STUD

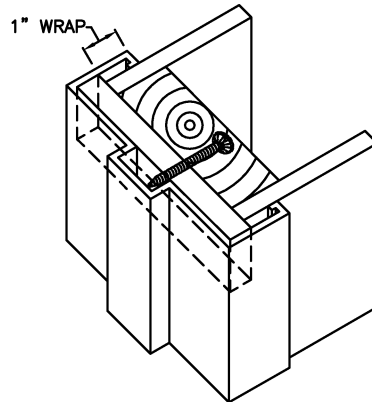

OPTION W-WS2
WRAP WOOD STUD

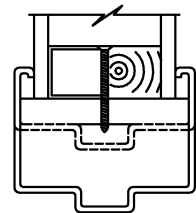

2" OR 4" HEAD ANCHOR
WHERE REQUIRED

NOTES: ADDITIONAL WALL THICKNESS UP TO 8³/₄"
CAN BE ACCOMMODATED.
CONSULT FACTORY FOR DETAILS.

ROUGH OPENING WILL BE AS FOLLOWS:
OVERALL FRAME WIDTH MINUS 2"
OVERALL FRAME HEIGHT MINUS 1"

ALL ANCHOR HOLES IN DOOR STOP ARE FACTORY
PRE-DRILLED AND COUNTERSUNK.



FIBERGLASS DOOR FRAME
WRAPPED WALL ANCHORING DETAILS

DATE 2/25/20	SCALE NONE	
DWG NAME WRAPANCHORING	DRAWN BY BG	